

Additional Remarks on the Purification Iconography at the Graeco-Roman Temples of Upper Egypt

Wessam Fekry Ibrahim Moussa

Tourist Guidance Department, Faculty of Tourism and Hotels, Matrouh University

ARTICLE INFO

Abstract

Keywords:

Purification
Scenes, Graeco-
Roman Temples,
Upper Egypt,
Ancient Egyptian
Symbols.

(JAAUTH)
Vol.23 , No.1 ,
(2022),
pp.16 – 42.

This paper provides an analytical comparative study of specific scenes depicted on the walls of six remarkable Graeco-Roman divine temples of Upper Egypt; Dendera, Esna, Edfu, Kom-Ombo, Phila and Kalabsha. Indeed, employing the creative vocabulary at their disposal, the Ptolemies followed by the Roman Emperors adorned those great temples' walls with reliefs and scenes of high symbolized value. Thus, the study focuses on certain depictions where the Ptolemaic and Roman rulers were portrayed wearing garments, emblems, traditional Egyptian symbols, and being purified typically as Egyptian Kings.

The methodology followed aimed at investigating these scenes as well as comparing them with the corresponding ancient Egyptian scenes in terms of location, details, and depicted characters. Findings revealed some distinctive innovations and developments as well as asserting that this kind of representation was more than just a religious tradition, it sometimes has a political character which justifies the purposeful ideological and propaganda value associated to it. The kingship's prestige is confirmed by these expressive visual narratives, which, based on the field study, are often in sites where the public had unfettered access. All with the goal of being accepted as legitimate kings and successors of the ancient Egyptian kings.

1. Introduction

There is a particular characteristic that all the kings of the Ptolemaic dynasty and many Roman rulers share, they performed ritual and religious responsibilities that an Egyptian king was supposed to accomplish, namely constructing, renovating, and adorning sanctuaries, chapels, and religious temples¹. Consequently, there are still numerous divine temples built or decorated by them as, Dendera, Edfu, Kom-Ombo and Phila.

The scheme of heavenly buildings demonstrated the rulers' appreciation of traditional Egyptian religious activities while projecting an image of their own supremacy in Egypt. Accordingly, the administrative dominance of Egypt by those foreigners was supported by clever and effective use of the artistic symbolism of Egyptian temples as an adaptive system that affiliated them with the local political heritage².

There are several extremely notable instances of how rulers during the Graeco-Roman Period employed the customary visual themes of ancient Egyptian culture to disseminate and enforce their political ideologies; one of them is the notable king's purification scene.

The purification scene as the main subject of the study is part of a set of four scenes that are organized in sequential order. Starting with the Royal Exit, the king is portrayed leaving the palace to go to the temple. The Purification scene follows, in which two gods pour water over his head. Following that is a Coronation scene in which the king is crowned by two deities. Finally, gods introduce the purified and crowned king to the main deity of the temple³.

This kind of depiction informs us about a crucial aspect of Egyptian religious dogma in which the purification was required before one could enter the temple even the King. Gardiner released a paper on the subject in 1950⁴, and it is still the most frequently cited source. Furthermore, Gardiner's investigations didn't cover the Graeco-Roman temples. Besides, recent studies did not investigate in details the already available scenes, they were satisfied with average scenes as an example for their study⁵. Some gave few instances of scenes in two or three of the important temples, such as Edfu, Philae and Kom Ombo⁶. While others explained only the rite within their publications⁷. This shortage in the literature prompted the researcher to conduct large-scale extensive research about the purification scenes available in the Graeco-Roman temples of Upper Egypt, geographically from Dendera to Kalabsha, to decode its symbolism and reveal evidences to be among the rare investigations released after Gardiner publication in 1950. In doing so, the proposed study will contribute to the literature by fulfilling the following objectives:

- Investigate the scenes and compare them with their parallel in ancient Egyptian temples.
- Outline characteristic features of the ancient Egyptian and Ptolemaic-Roman scene format to identify similarities, modifications and exceptions.
- Highlight the aesthetic impact and ideological meaning of purification scenes.
- Interpret the Ptolemaic-Roman political philosophy and decoding their messages.

2. Literature Review

2.1. The Scene

The king occupies the center of the scene. He is flanked by two gods, mainly, Thoth and Horus, who are standing on a plinth, raising their arms and pouring on the king the water contained in a vase known as the Hs vase. Thoth is behind the king, while Horus, is in front facing the king. Each of the two vases pours on either side of the king a jet of water, ankh, or a thin chain of the alternating ankh and was signs. The Hs vase, most likely contains qbhwt m nswt the '*purifying water from the Nile*.' It is also the vase that Hapi carries on his hands or sets on a tray as a symbol of the flood⁸. Thus, showing the water of libation as a trickle of *Ankh* and *Was* signs emphasizes the benefits of the cool (kbhw) and fresh (rnpy) Nile flood water⁹. Traunecker also pointed out that the waters of libation at Edfu, which originates from Elephantine, are consequently referred to as 'anx-was'¹⁰. Gordon and Schwabe¹¹ contended that when both anx and wAs occur, they may share a sense of regeneration or rejuvenation.

It's a remarkable feature, for which no explanation appears forthcoming, as Gardiner confirmed in 1950, that the *hes*-vase, not any other, is invariably used at these royal purification sites. In practice, Gardiner¹² have accessed all sufficiently visible instances, either through publications or photographs, in doing so he concluded that this kind of vessel was clearly designed only for ceremonies honoring the king personally.

2.2. Purification of the living King

Ancient Egyptians conducted intensive water purification practices. The living King was purified in a number of ceremonies, Blackman summarized these ceremonies as follow¹³:

(a) In infancy.

A purification ceremony was done to prepare the child for kingship. The procedure, which consisted of washing the child with water, was not only a purification rite, but it also handed on to the future king some divine characteristics and vital force.





(b) Before coronation.

The incoming ruler was purified in the Cool Pool and washed his face in the waters of Nun, where the sun god washed his face. He was compared to the sun god, who was implored to see him as a son, as a result of this conduct.

(c) At coronation.

According to Gardiner this rite which belongs to a series of incidents in a real or symbolic coronation ceremony is represented for the first time at the temple of Medinet Maadi of the Twelfth Dynasty¹⁴. In his sample, the earliest occurrence of this scene dates from Hatshepsut's reign. Later findings, however, provided more evidences from the Old Kingdom¹⁵.

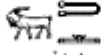
He, Gardiner, explores a number of scenes representing other kings such as, Thutmose III, Seti I, Ramesses II, III, and IV being purified by gods who hold the *hes-vase* and pour water over the king's head. However, it was more common to display symbols for the purifying streams' promised benefits; in certain cases, we just see the vivifying ankh signs, but this is more frequently alternated with *was* symbols, symbol of power¹⁶. Blackman suggests that this kind of purification was a reenactment of that ceremony performed during infancy, both have some resemblance to primordial conceptions of royalty and fertility¹⁷. The gods said to the king, "be pure together with thy ka, (namely) thy great majesty as King of Upper and Lower Egypt, thou live [eternally]"¹⁸

				
<i>uab ta</i>	<i>hna ka-t</i>	<i>sat-t</i>	<i>wr n</i>	<i>suten nt</i>
thou art purified	with thy ka	(for) thy dignity	great	of King of Upper and Lower Egypt

(d) Before officiating in a temple.

Before entering the temple to engage in any ceremony, the king would have to be purified in the House of the Morning *pr-dwAt*¹⁹, which consisted of sprinkling the king with water that sometimes-contained natron.

(e) At a Sed-festival.

The washing of the king's feet and hands appears to have been given special attention at this festival.

In general, ritual purifications, temporarily gives man a divine virtue that's why it must be repeated at the beginning of each ceremony²⁰.

2.3. Purpose of the rite

Gardiner believed that purification was a prerequisite for kingship, and named the rite "The Baptism of Pharaoh" drawing an analogy to Christian baptism, which serves as an introduction into a suitably legitimated religious life through a symbolic cleaning by means of water²¹. Examining the texts accompanying to the scenes reveals an even closer parallel to the ceremonial purpose of Christian baptism. Not only does the ceremony provide ritual cleanliness, although in Christianity, this involves the cleaning of mortal sin, while in the Egyptian ritual, such purification was largely from material pollution, but it also ensures that the person for whom the rite is done is reborn²².

The actual purpose of the hes-purification or the baptism of the Pharaoh is actually appeared in the Karnak example which dates back to Seti I where the text said: “*I purify thee with life and dominion, that thou mayst grow young (rnp.k) like thy father Re and make Sed-festival like Atum, being arisen gloriously as prince of joy*”. According to the inscription the king is purified by the symbols of life and power in order to be as young, fresh and powerful as God Re, the purification is also associated here with the Sed-Festival which primarily was held to rejuvenate the king’s strength. The act will enable the king to emerge gloriously as the prince of joy, this could emphasize the transformation of the recipient to be acceptable and pleasing to Gods.

From another view, this ceremony is nothing other than an image of the divine act of regeneration, a rite intended to make the king momentarily at least, for the duration of the office, a god-son capable of rendering divine duties to his father²³.

Gabriel suggested that the rite is acted by officiating priests who wore the masks of Thoth and Horus. The selection of Thoth and Horus is due to their vital roles in the Osirian myth. These gods were the ones who performed Osiris's resurrection rite over his body. Washing Osiris' limbs and body, brought him to life again. This clarifies the relation between washing with water and rebirth²⁴. Thus, purification or libation with the water of life and power was an obligatory ceremony for the rebirth of the new, clean and strong defied monarch.

Generally, it seemed that the water that baptizes the king implies more than purifying, such a ceremony is a validation of the true prerogatives to be pursued with force and tenacity²⁵. In another word, the magical charge of revitalizing force is transmitted via the bath of life and power. Thus, the recipient becomes regenerated, like the god, purified of all previous defilement, he can officiate fruitfully, like a young god born to his father.

3. Methodology

This study adopts the content analysis approach to analyze and compare the collected primary and secondary data concerning the purification scene within the Graeco-Roman temples of Upper Egypt of Dendera, Esna, Edfu, Kom-Ombo, Phila and Kalabsha, which are organized within this paper according to their geographical order (Map.1). The aim of this method is to increase the understanding of the significance, symbolism and interpretation of such scenes. The stated temples were selected as the sample for the field research owing to their preserved conditions, richness of their details, and recommendations of proficient tourist guides.

The secondary data was collected through a deep investigation to the literature that cited both Ancient Egyptian and Graeco-Roman purification scenes, while a series of self-visits to the selected Graeco-Roman temples were conducted to collect the primary data, each part and every wall in the targeted temples were carefully examined, and wherever the scene was found, it was monitored and photographed immediately to record the required details from each scene (i.e., Location, condition, the represented king, the accompanied Gods, the purifying stream, count of the stream signs, motion flow, etc.). This field study led to an inventory of about 26 scenes, each one is identified by an ID bearing the first two letters of the temple then number of the scene (see Table.1; Temples Plans, 1-8). Then the collected data were summarized and tabulated (see tables 1,2) in order to achieve the objectives and formalize the results.

4. Analysis and Comparison

As mentioned above, the intended reliefs represent the purification ritual that was part of Egyptian coronation ceremonies. It took place in a sequence of ritual acts that culminated in the new king's presentation to the realm's supreme god. The following table 1 examines and analyzes this kind of scene while table 2 compare it to the ancient Egyptian model to demonstrate the

interaction of verbal and visual depiction in Egyptian art during the Graeco-Roman era, and also to clarify the symbolic significance of certain illustrations which were utilized to convey precise ideological influences from the Ptolemaic-Roman perspective.

Table 1: The Recorded details of the 26 Monitored Scenes. © Author

Scene ID	Temple	location	outer parts	inner parts	king	Condition			Custom					Exhibit the main divinities of the temple or other deities	No of ankh	No of was	Beginning of the stream	Free hand				Occupied hand					King face to Horus	The king's orientation and motion flows
						Damaged	Poor	Good	Shendyt kilt	The bull tail	Fake beard	Nemes	Cap crown					Offering	Adoration	Infront	Back	Fingers/inward	Fingers/outward	Infront	Back	Correct anatomy		
DA1	Dendera	Outer Hypostyle, Intercolonnar wall	√	x	?																							
DA2		Outer Hypostyle, Intercolonnar wall	√	x	Nero	x	√	x	√	√	√	√	x	Winged disk			stream of water	√	x	x	√	√	x	√	x	√	√	w
DA3		Exterior, East wall	√	x	?	√																						
DA4		Exterior, West wall	√	x	Augustus	x	√	x	√	√	√	√	x	x	25	23	adoring hand	√	x	x	√	√	x	√	x	√	√	s
ES5	Esna	Façade, Intercolonnar wall	√	x	Titus	x	x	√	√	√	x	x	√	Menhit	22	20	ankh	x	√	√	x	√	x	x	√	x	√	NW
ED6	Edfu	Birth House, Exterior	√	x	Ptolemy IX	x	√	x	√	√	x	x	√	x	20	18	ankh	x	√	√	x	x	√	x	√	√	√	E
ED7		Birth House, Southern Exterior of Inner Vestibule	√	x	Ptolemy IX	x	√	x	√	√	x	x	√	x	20	20	ankh	x	√	√	x	x	√	x	√	√	x	W
ED8		Birth House, Northern Exterior of Inner Vestibule	√	x	?	√																						
ED9		Forecourt, West South wall	√	x	Blank Cartouche	x	√	x	√	√	√	√	x	x	30	28	ankh	x	√	√	x	x	√	x	√	√	√	W
ED10		Forecourt, East South wall	√	x	Blank Cartouche	x	√	x	√	√	√	√	x	x			ankh	x	√	√	x	x	√	x	√	√	√	E
ED11		The Outer Hypostyle Hall	√	x	Ptolemy VIII	√																						
ED12		Corridor	√	x	?	√																						
ED13		Corridor	√	x	a Ptolemy?	x	√	x	√	√	√	√	x	x	20	18	ankh	x	√	√	x	x	√	x	√	√	√	N
ED14		Corridor	√	x	?	x	√	x	√	√	√	√	x	x			ankh	x	√	√	x	x	√	x	√	√	√	N
ED15		Corridor	√	x	?	√																						
ED16	Exterior of the Girdle Wall	√	x	Ptolemy XI	x	x	√	√	√	√	x	√	x	20	20	ankh	x	√	√	x	x	√	x	√	√	√	√	N
KO17	KOM OMBO	Façade, Intercolonnar wall, the hypostyle room's façade	√	x	Ptolemy VIII or Ptolemy XII?	x	√	x	√	√	x	x	√	Horus	25	25	ankh	x	√	√	x	x	√	x	√	√	√	SE
KO18		Façade, Intercolonnar wall, the hypostyle room's façade	√	x	Ptolemy VIII or Ptolemy XII?	x	√	x	√	√	x	x	√	Sobek			ankh	x	√	√	x	x	√	x	√	√	√	NW
KO19		Inner Hypostyle, Room B, west wall	√	x	Ptolemy VIII or Ptolemy XII?	x	x	√	√	√	x	x	√	x	34	33	ankh	x	√	√	x	x	√	x	√	√	√	NW
KO20		Room C or Outer Vestibule, north wall	x	√	Ptolemy VI	√								two vultures			ankh		√	√			√		√	√		NW
PH21	Phiaë	Birth House. Colonnade. Intercolonnar Walls	√	x	Ptolemy XII Neos Dionysos	x	√	x	√	√	x	x	√	x			ankh	x	√	√	x	x	√	x	√	√	√	N
PH22		Temple of Isis, Room I	x	√	Ptolemy II Philadelphus	x	√	x	√	√	x	x	√	x	10	10	stream of water	x	x	√	x	x	√	x	√	√	√	N
PH23		Temple of Isis, Exterior East Wall	√	x	Augustus	x	√	x	√	√	√	x	√	x	22	20	?	x	√	√	x	√	x	x	√	x	√	N
KA24	Kaldbsha	Hypostyle. Façade, Intercolonnar wall	√	x	Pr-Aa	x	√	x	√	√	√	x	√	Horus	24	24	ankh	x	√	√	x	x	√	x	√	√	√	N
KA25		Outer Vestibule	x	√	?	x	√	x	√	√	√	x	√	x	water		water	x	√	√	x	√	x	x	√	x	√	w
KA26		Outer Vestibule	x	√	?	x	√	x	√	√	√	x	√	x	water		water	x	√	√	x	√	x	x	√	x	√	w

4.1. Commentary on Table 1





- The study listed 26 royal purification scenes. Eleven examples are Ptolemaic (Nos. ED6, ED7, ED11, ED13, ED16, KO17, KO18, KO19, KO20, PH21, PH22), five are Roman (Nos. DA2, DA4, ES5, PH23), the fifth is with a Pr-aA cartouche (No. KA24), as for other ten scenes, the king is unknown. This is either because the cartouches are damaged or being blank (i.e., ED9, ED10).
- The most ancient of the scenes comes from the reign of Ptolemy II (285 – 246 B.C) in the temple of Isis at Philae (No. PH22), while the most recent is recorded in the name of Titus (79–81 A.D) in the temple of Esna (No. ES5). It thus could be concluded that during the second half of the first century A.D., this ritual stopped being represented on the temple walls, most likely due to political conditions, but it could also be a matter of artefact survival, and if there were more surviving parts such as pylons, more recent Roman scenes of that kind might be recorded.
- The condition of most of the study sample, approximately 16, is poor and requires immediate intervention for preservation, 7 instances are partially or entirely damaged and need restorations (see temples plans. 1-8, IDs shaded in dark grey), while only 3 are in fairly good condition.
- The purifying stream was more common to display symbols, in most cases, ankh (life) and was (dominion) hieroglyphs. The exception is found in a Roman scene in Dendera (No. DA3) where the Djed pillar appeared in the stream. Unfortunately, the scene is partially damaged, and the king's cartouche is not clear, but from its corresponding location to scene NO. DA4, it might be concluded that the recipient is Augustus (31 B.C –14 A.D). The extremely rare appearance of Djed here is very interesting. It is curious that this scene was not mentioned before in the literature, and the researcher did not find an explanation for that. So, to interpret the significance of adding the **Dd** pillar to the stream, it is important to highlight it first. The Djed is one of Ancient Egypt's most fascinating symbols. It is described by Faulkner²⁶ as a cult item imitating a tree trunk with lopped-off horizontal branches, devoted to Osiris, Ptah, and Sokar, he translates it as 'stable' and 'enduring'. Alan Gardiner argues that it resembles a column simulating a bundle of stalks bound together. Despite this, he characterizes the upper piece of the Djed, as vertebrae. It is utilized in the term psd, meaning back or spin²⁷. As reported by Wallis Budge²⁸, the Djed is Osiris's earliest emblem, representing commonly his backbone and body. He asserts that Osiris was initially represented solely by the Djed and that he really had no other forms. He considers the Djed hieroglyph to be a traditional portrayal of a portion of his spinal column, and its meaning is "to be stable, lasting, permanent, set firmly, and enduring"²⁹. Because Seth knocked down this mythical pillar, the king has the first duty to ritually straighten it in certain ceremonies, notably that of his coronation, then at the time of his jubilees. This renewed victory of the luminous life forces over the nocturnal forces of Seth allowed Osiris to declare: "I am he who stands behind the Djed pillar", implying that the deity was then the pillar of Egypt and the world, the principle linking the earth to the celestial world³⁰. Therefore, more probably the addition of the Djed Pillars to the bath is due to a political reason, with the assumption that the recipient is Augustus (31 B.C –14 A.D) hence incorporating this sign gives the ritual another significance, as though it grants the new king not only life and dominion, but also the stability he seeks for the new era. The king receives more abilities and benefits symbolized by the Djed that associated, most likely, to Osiris. Once more, to ensure the value of the ceremony as a prerequisite for the rebirth of the new ruler.

- In Kalabsha (Nos. KA25, KA26), only water was poured from the hs-vases, despite being more recent, the two incidents are not unusual to Egyptian customs. On the contrary, it appears that the artist in each desired to conform and revive old school traditions.
- The recorded total number of ankh signs in the preserved scenes is greater than the number of Was symbols. Previous studies neither addressed the quantity of these signs nor interpret the phenomenon. However, the extended number of the ankh is probably related to the essential symbolism of the rite, which is associated with life and rebirth of the new king.
- A new noteworthy feature is observed, which is the commitment to place the ankh symbol in front of the king's mouth in all portrayals, whether Egyptian or Graeco-Roman. Somehow this condition emphasizes the contribution of this ceremony and its relation to the new life. Ankh here is indeed, as mentioned in the literature, the breath of life.
- Purification scenes are found in public areas (i.e, outer hypostyle halls, exterior walls, façades, exterior walls of the birth houses and forecourts, see Table.1), accessible to temple visitors, in 22 cases of the sample, thus helping to proclaim, even to those who didn't know how to read the written inscriptions, the ideas of legitimization and universal domination linked to those visual narratives. These images have unquestionable ideological value: they indicate and demonstrate the Egyptian gods' acceptance and choice of the foreigner rulers as worthy, legitimate, and justified successors to the autochthone pharaohs. The visual tale is designed to highlight the primary divinities of Egypt's express support of the concept of royalty in their role as guardians of the monarchy and the realm.
- Majority of the wall scenes represent the active deities, or priests, with one hand, usually behind, holding the vessel from which symbols of libation or water are issued. The other hand is completely empty and regularly in the form of adoration. However, some exceptions are noticed in Dendera;
 - The free hands motions in the Dendera examples are different (DA1, DA2, DA4); they are offering rather than adoring.
 - Nonetheless, one of these scenes (DA4) reveals a significant feature. A small representation of a hand is fitted at the very beginning of each stream issued out from the vessels. According to Ivanov³¹, the Egyptians saw the adoration part of this image as vital, and it had to be depicted even while the deities' hands were changed. In addition to the opinion of Ivanov, the researcher believes that the representation of the hand emerging from the mouth of the vessel may not intended only to represent adoration, especially that it appears as if it is holding the ankh sign. It reminds us with the usual scene of gods and goddess pressing the ankh against the soul's lips to rejuvenate it. Perhaps it represents the same idea of revival and rebirth that the gods do when presenting the ankh to the deceased to bring him back to life. In this case, the water bath confirms the idea of rebirth and resurrection of a new deified king.
- Additional findings can be found in the gods' occupied hands, which are holding the vases to pour water. There are potential differences in which hand is holding up the vessel as well as variations in the turn of the wrist. It is noticed that whenever the arms of the gods that carry the vases are depicted backward with inward fingers, the shape of the arms appeared anatomically incorrect or twisted in an uncomfortable and abnormal way (ES5, PH23, KA25, KA26), contrary to the indication of Ivanov³² who stated that this incorrect shape is found in pre-Ptolemaic temples only (see fig. 1). In

the cases of Dendera, the fingers are inward, yet the anatomy of the arms are correct since the hands holding the vases are portrayed ahead and the free hand behind (figs. 2, 4).

- Scene KO20 at Kom Ombo contains a remarkable detail as vultures introduced at the top of the depiction. This characteristic is relatively rare in the Graeco-Roman Period but appeared in older examples, therefore it appears that the style at Kom Ombo was to incorporate traditional features into the framework.

Table 2: A comparison between the scenes of purification depicted on Ancient Egyptian and Graeco-Roman Temples of Upper Egypt

Criteria	Egyptian Temples (based on Gardiner's study)	Graeco Roman Temples (based on the researcher field study)
Location of the scenes	In many cases the scene is located in inner parts of temples, i.e., inside shrines and inner rooms (Gardiner, 1950, Nos. 1, 4, 6A, 11, 12, 18, etc.). It doesn't appear to make a difference which register of the wall the scenes are arranged on.	Generally, on the outer parts of temples; in corresponding locations (as in Dandara and Edfu) frequently placed in a symmetrical pattern, commonly on the first register; more often associated with doorways. Merely in 4 instances the, scenes are found in the interiors (KO20, PH22, KA25, KA26)
King's Custom	Sometimes only the wig or wearing Skull Cap, Nemes, Blue Crown; often in composite custom especially during the Ramesside period.	The king always wears either a Skull Cap, which is in most cases, or Nemes headdress; sometimes a corselet that is held up by braces, a simple unornamented kilt and the bull's tail at the back
Main Gods and their positions.	Usually Horus and Thot; rarely Horus and Seth (Nos, 13, 17, 27), Amun and Re-Harakht, or Mont and Atum (Nos. 31, 32). Horus is always in front of the king while Thot or Seth is behind him. (rarely Seth appeared in front of Seti I as in the temple of Abydos, fig.1) Gods are represented standing either on podiums, or on the floor (see fig.1).	Exclusively, Horus and Thot. In all cases Horus is in front, except in two instances the king is facing Thot in the temple of Edfu (No. ED7) and in Dekka Temple. Gods usually represented standing on podiums.
The Purifying Stream	In a few rare examples, gods poured water over the king's head (examples Nos. I, 6A, 23, 32), in some cases only  (Nos. 5, 6, 7, 13, 26), more often the Ankh alternates with  (Nos. 2, 3, 4, I7, 27, 28, 29)	Commonly  alternates with  , except in Dendera (No. DA3, fig. 3) the <i>Ankh</i> alternates with <i>Was</i> and the <i>Djed Pillars</i> - this is the only example of that type . In only two scenes, gods poured water (Nos. KA25, KA26)

4.2. Commentary on Table 2

- The Graeco-Roman rulers preferred the outer places to express their dignity through expressive visual records, often located in free access spaces to the majority of the public.

- During the purification rituals, Ptolemaic and Roman rulers were portrayed by costumes, emblems, and all royal insignias founded by their predecessors, however, it appears that they preferred the simpler costume style.
- In the Graeco-Roman ones, it seems that the artist wanted to follow the same traditions and keep the appearance of the king as the tallest, but he placed other gods on podiums to preserve the symmetry of the scene.
- According to the 34 scenes identified by Gardiner, the deities linked with this subject are often Horus (facing the king) and Thoth (behind the king), in three instances Seth appeared in place of Thoth, while other god pairs appeared only twice³³. Gardiner didn't refer to the case where Seth appeared in front of the king in Abydos. In all of the Graeco-Roman cases, only Horus and Thot were represented to perform the ritual where Thoth stands behind the king and Horus in front of him. However, the study revealed some exceptions, at the temples of Edfu and Dakka where Thot is portrayed in front of the king; not behind him. The exception in Edfu (ED7, fig. 7) on the wall the Birth House, is observed and recorded by the researcher according to Ptolemy IX's (80 – 51 B.C) position and flow of motion. The Dakka's example is mentioned by Ivanov³⁴ where he related the inversion to being Thoth the main shrine's god.
- Earlier attempts assumed that Thoth represented as a substitute for Seth³⁵. On the other hands, further Astro theological motif can be seen in Gardiner's explanations who hypothesized that the *hes* purification was "quadrilateral", not "bilateral", even though all four gods, of the cardinal points (*Horus, Seth, Thot, Dwen-anwey*) were not portrayed since it was not artistically suitable. Gardiner strengthen his opinion by the following inscription found with the purification rite that performed before an 18th dynasty statue of a deceased:³⁶



Wab.q wab 1r wab.q wab 4th wcb.q wab 9Hwty wab.q wab 8wn anwy

"your purification is the purification of Horus, your purification is the purification of Seth, your purification is the purification of Thot, your purification is the purification of Dwen-anwey"

Gardiner described the scene's quadrilateral connotations as a wish to show the king's rule over the four cardinal points³⁷. The pairing of Horus and Seth, as seen in the crowning reliefs, would have suggested a north-south approach. So, Thot here is not a substitute for Seth, instead his presence with Horus would have been a broad indication of the virtual presentation of the two missing members of the four. As a result, the idea that Thoth has taken the place of Seth is a misconception. Jéquier suggested that Horus and Thoth's selection may have been inspired by their replacement for the two creator gods, Sia and Hu, who travelled with Re on the solar boat and were responsible for the Sun's resurrection from primordial waters³⁸. He also assumed that if Thoth and Horus, in other words Sia and Hu, the heart and the tongue of the supreme divinity, are the agents which make effective for the resurrection of the sun that plunge into the waters of an extraterrestrial world, they can also cause the divinization of the one who must perform the daily rite of divine worship³⁹. Labrique has cited an Edfu example of pharaonic purification in which the inscriptions link Thoth and Horus to Geb and Ra, correspondingly⁴⁰. More recently, another explanation is added by Ivanov who stated that according to the direction and movement of the royal figure, Thoth (lunar, hence night god) stands "behind" the king, while Horus (solar, daily god) stands "in front" of the king. Because both deities have avian characteristics, it is possible to associate them with the night and day sky. As a result, the king's posture and movement depict a shift from night to day, as well as **a symbolic upward movement from the "terrestrial to the celestial"**⁴¹.

- In the Egyptian model, when the ritual was actually carried out, water was poured over the king's head, and this is shown in a few rare occasions (i.e., Amenophis III at Luxor temple, Ramesses III purification in Medinet Habu, rear room). However, it was more common to display symbols for the purifying streams; in certain cases, only the ankh, the symbol for life (i.e., Hatshepsut at Karnak, room XII, north of granite Shrine, Ramesses XI at the Temple of Khonso, east wall of the hypostyle hall), but this is more frequently alternated with was, symbol of power, (i.e., Ramesses II at Karnak, hypostyle hall, east wall, Ramesses IV at Temple of Khonso, bark-shrine, east wall). As the Was symbol is depicted standing between earth and heaven on each side of several royal monuments, Gardiner strengthened his theory of the Quadrilaterals. He believed it can be regarded as a specific power of each of the cardinal gods. As a result, it appears that the rite was designed to transfer a significant portion of the dominion of the deities who supervised over the four corners of the globe to the King (Gardiner 1950, p. 12)⁴². Depending on Gardiner explanation the Was here refers not only to the absolute power but also to the new dominion given to the king by the deities of the globe.

4.3. The Significance of ankh and wAs Symbols used in the stream

The ancient Egyptians used a vast range of religious and magical symbols in their art, considering that they had the power to change reality in certain ways. Among those regarded as the most powerful were ankh, and wAs scepter⁴³, which can be found everywhere from amulets to architecture that were commonly used in combination in inscriptions and can be found on wall reliefs together or separately. In each of these cases, the form represents the concepts of eternal value: the ankh symbolized life, and the wAs power⁴⁴.

4.3.1. The ankh

The Ankh is one of Ancient Egypt's most well-known and extensively used symbols. It is a term for the physical life, it also refers to "*eternal life*"⁴⁵ or "*breath of life*"⁴⁶, and appeared usually in hieroglyphic text and iconography throughout ancient Egypt. The symbol dates back to the Early Dynastic Period, when the cults of the deities Isis and Osiris were formed (2920-2575 B.C.)⁴⁷. The ankh's exact origin is uncertain⁴⁸. It is labelled as S34 on Gardiner's list of hieroglyphic signs, who places it in the category S for crowns, staves and clothing and just after S33, the hieroglyph for a sandal. Thus, Sir Gardiner believed it evolved from a sandal strap. He arrived at this conclusion because the Egyptian word for "sandal" was "*nkh*," which came from the same root as "ankh," and because the sandal was a part of daily life in ancient Egypt, and the ankh sign came to symbolize life. However, this theory was not widely accepted⁴⁹.

Whereas Chevalier and Gheerbrant⁵⁰ presume that the ankh sign's loop represents the solar eye of Ra arising from an eastern horizon, others attempt to derive the distinctive emblem from the image of a cow vertebra (fig. 17) as Gordon and Schwabe⁵¹ who showed that the *Ankh* and *Was* symbols may have originated from anatomical features found in bulls' spines. Their work describes how there is evidence that ancient Egypt was a cattle-based civilization, this opinion was discussed before by Budge⁵², who explained the importance of bulls to the Egyptian kings.

Mcdonald⁵³ believed that the ankh symbol is a relatively simple motif that has both direct and indirect relationships with the Nilotic lotus. It also signified the creative seed and the vitalizing breath of the sacred phallus and solar eye of varied Egyptian lotus-gods, such as Nefertum-Ra, Horus-Ra, or Osiris-Ra⁵⁴.

According to another theory, the ankh is originated from the goddess Isis' belt buckle, symbol *tjet* or the "knot of Isis"⁵⁵, which is considered more likely, but it is still not generally accepted⁵⁶. Wilkinson believed that ankh has a variety of meanings that could be expressed

in different ways. It offered a diverse range of symbols centered on the core concept of "life"; from "life-sustaining water, air, and food to the life-force in lush plant growth and sexual potency". The widespread representational approach in which ankh signs were used as a visual approximation of streams of the life-giving liquid, as in the depiction of ceremonial purification, informs the relationship with water⁵⁷.

Mark⁵⁸ declared that it resembles eternity, the rising sun, male and female concepts, the cosmos, and the earth. Carrying the ankh was like holding the key to the secrets of presence. The looped cross represented the union of opposites (male and female, earth and heaven), as well as the extension of earthly life to eternity. It's no surprise it was utilized by the Christians as a symbol for their religion in the 4th century A.D.

Others argue that the ankh has been over-interpreted but instead it resembles the Nile's pivotal role in the country. The oval head is seen to demonstrate the delta of the Nile, while the vertical sign indicating the river's course, and the eastern and western arms reflecting the country's two sides and their eventual unification⁵⁹.

4.3.2. The w3s Scepter

It is a stick with a forked end and an animal head on top. It is conveyed as a symbol of power and authority by several gods, who in various depictions pass it on to the ruler⁶⁰. Gardiner (1950) believed it represents "divine power" and has the same meaning as "dominion". Some believed that it has several related meanings, such as: the authority or right to govern and control; sovereign authority; kingship; order, controlling chaos; acquisition, assets, and the territory possessed by a ruler^{61 62}. Thus, when the gods or kings as their representative held the staff, w3s referred to sovereign rights or practicing control over the world and keeping it in order. It symbolizes divine power when referring to the gods. Regarding its presence during coronation ceremonies, it represents the power assigned to the king by the gods to have dominion over the world and all it contains. The king's dominion implies that he possesses divine power with the authorization of the gods⁶³.

In their research, Gordon and his team examined the anatomy of the bull's penis and other parts, the use of certain mammals' penis to confirm control, the bull as a sign of dominion, Egyptian comparisons between bulls and gods, royal individuals, celestial beings, other animals such as baboons, and the Egyptian principles of the male's role in fertility and reproduction. In light of their studies, they hypothesized a potentially broader socio-religious, or cosmological, value of ankh, was, Dd symbols⁶⁴.

Therefore, the *ankh* and *was*, respectively appeared in most of the illustrations, clearly indicate the following:

- Their revivifying and controlling value.
- The relationship of ankh with water.
- The water which flows from the hs-vases is a magic water intended to symbolize rebirth, new life, power, dominion and control.
- These symbols have a strong connection to the male reproductive system.
- The great sacred water that was poured to cleanse the king's sins and wash away his stray demons, flew from Elephantine and originated in the "primeval ocean".
- The Egyptian hieroglyphic forms offered flexible representations that could convey their symbolic values in a range of aspects.

5. Results

Purification or libation by Horus and Thot with the magical water of life and power was an obligatory ceremony for the rebirth of the new, clean and strong defied King. This rite was exploited by the Graeco roman rulers to express the following socio-religious and political messages:

- They are regenerated, like the god, purified of all previous defilement, they can officiate fruitfully, like a young god born to his father.

- The acceptance of those foreigner rulers as worthy, legitimate, and justified successors to the autochthone pharaohs and as guardians of the realm by the Egyptian Gods.
- Their rule over the four cardinal points, as well as the symbolic upward movement from terrestrial to celestial.
- The kingship's authority was asserted by these expressive visual representations, which were often in sites where the public had free access. The visual intellectual narratives justify the purposeful ideological political character and propaganda value associated to these representations.

The investigated details of certain scenes, of the sample, reflect innovations and developments rather than looking back to the past, i.e., the adoring hands at the mouth of the hs-vase, the djed pillar in the stream, the development of occupied and free hands motion and anatomy, the location of the scene and the quantity of the libation signs.

6. Conclusions

King's purification scene is clearly a recognizable ritual relief. For the Ancient Egyptians it was a prerequisite for kingship and an obligatory ceremony which symbolized the rebirth of the new king. The Ptolemies followed by the Roman Emperors adorned the temples' walls with reliefs of the same kind. The study assessed the extent to which such iconography influenced Greco-Roman policies; besides, it highlighted the main outlines of development in its symbolism whenever it occurs. This is accomplished through qualitative analysis and a comparative study, which compare the context of the original ancient Egyptian rite to the Ptolemies and Romans' later use of the same subject. Focusing on the development and use of this form of iconography in Greco-Roman temples, reveals that it was part of a larger pattern of "idealizing" old culture in order to "imbue" later native community. The study emphasized some characteristics of the post-scenes structure in order to find out similarities and innovations. Deep investigations imply that during the Graeco-Roman period, alterations were adopted and a standard framework for purifying scenes was developed. Such ceremony validates the real privileges that must be maintained through the bath of life and power which transmits the magical charge of rejuvenating force.

Acknowledgment

Foremost, I strength my sincere feeling to my family for their motivation, enthusiasm, encouragement, love and their endless patience. They accompanied me through the investigation tour to support and provide all the necessity to accomplish the work, specifically Dr Loay Alwalid who was the secret behind all the photographs taken for this study. This research would have never been accomplished without the help of my dean and colleagues, I would like to express my acknowledgment and deepest gratitude to all of them.

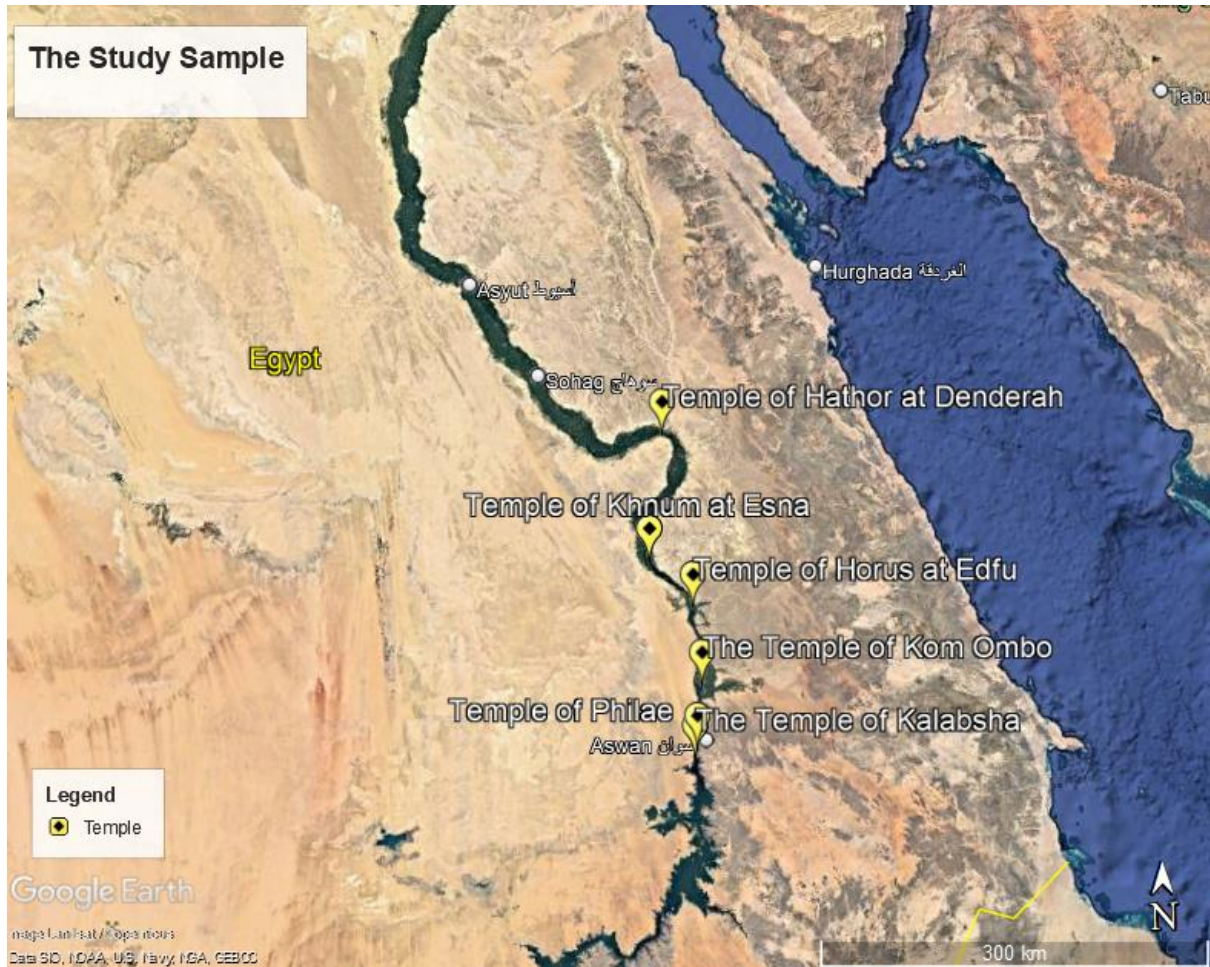

Map.1 The Selected Graeco-Roman Temples of Upper Egypt. © Author

Temples Plans^{65 66}:

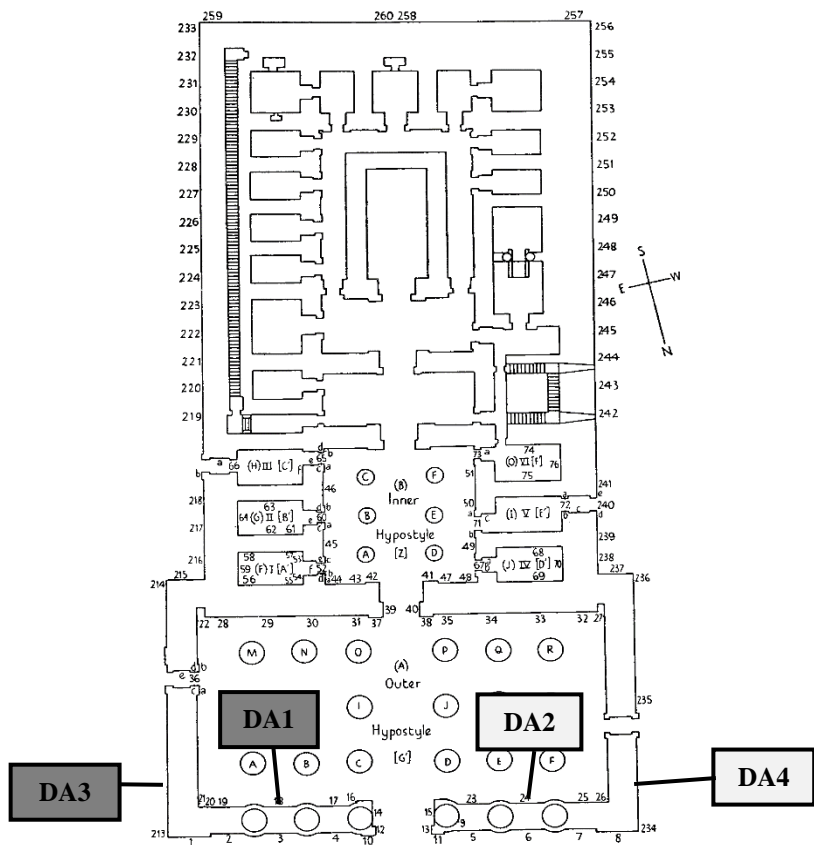

added by the Author. Plan.1. Dendera. Temple of Hathor. (Porter et al., 1939,

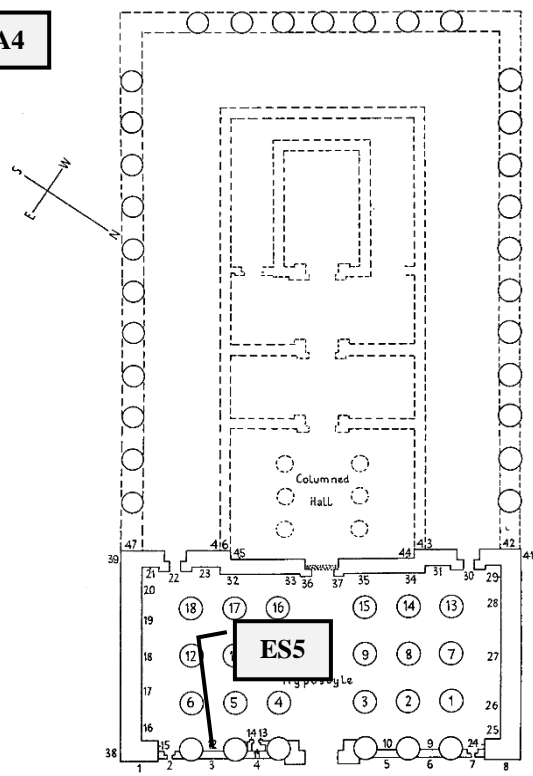

Plan. 2. Esna. Temple of Khnum. (Porter et al., 1939, p. 112). Scenes IDs added by the Author.

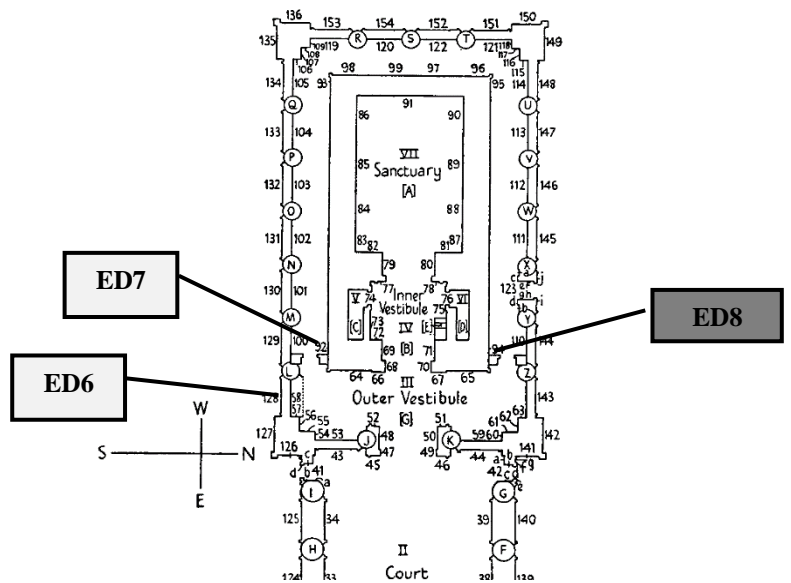

Plan. 3. Temple of Edfu. Birth House. (Porter et al., 1939, p.170). Scenes IDs added by the Author.

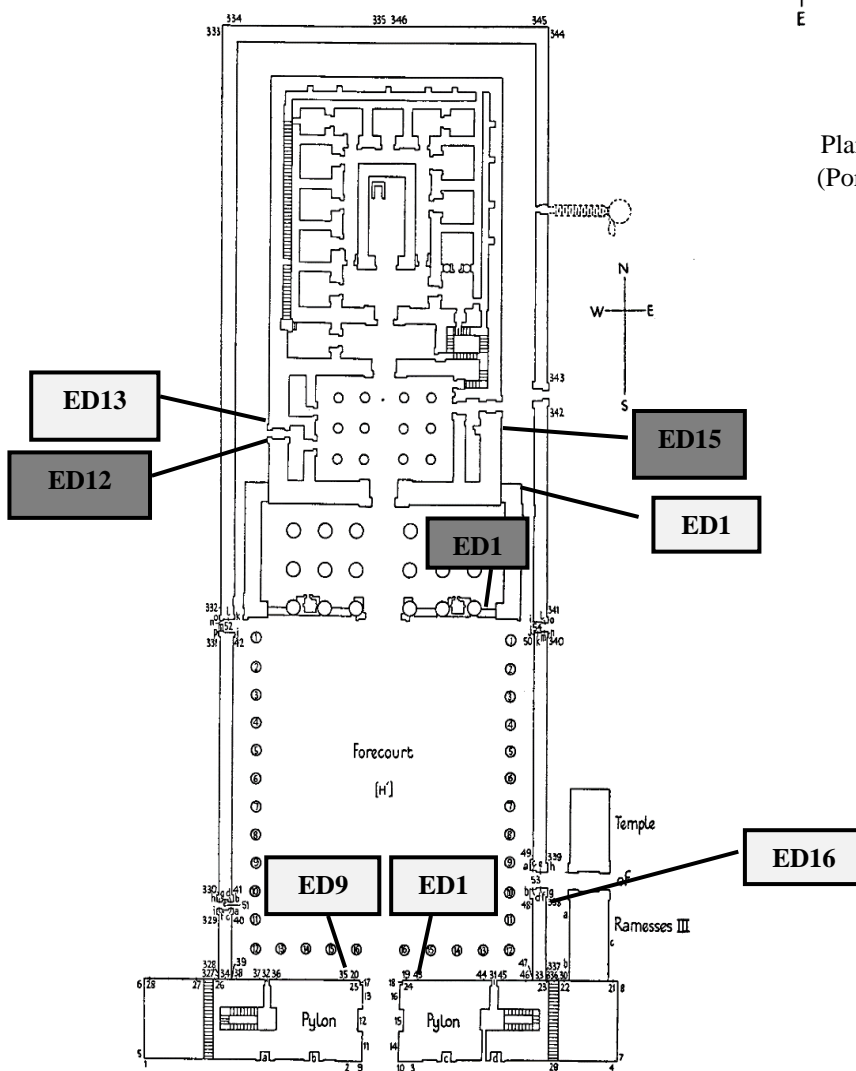

Plan.4. Edfu. Temple of Horus. (Porter et al., 1939, p.120). Scenes IDs added by the Author.

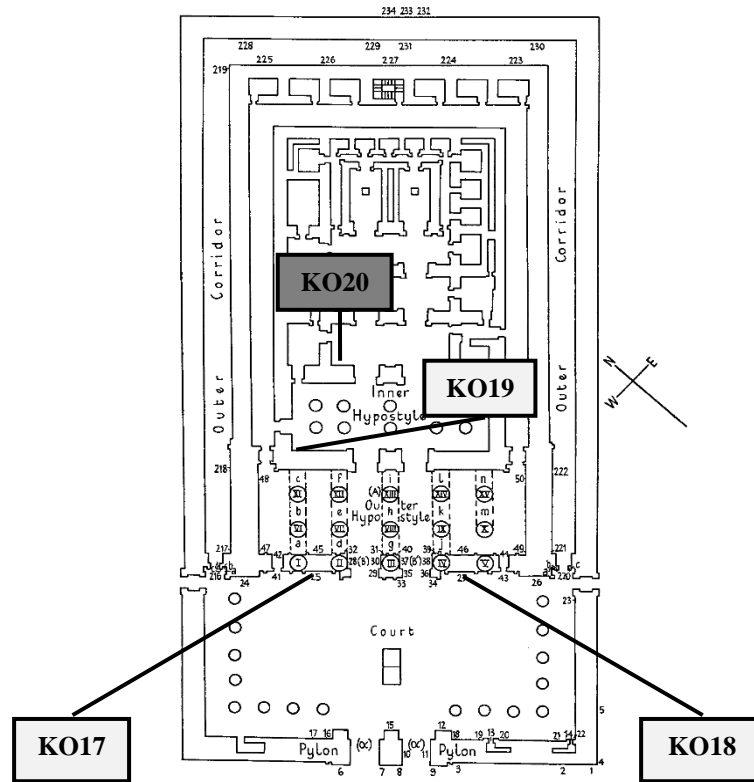

Plan. 5. Temple of Kom Ombo.
(Porter et al., 1939, P.180). Scenes IDs

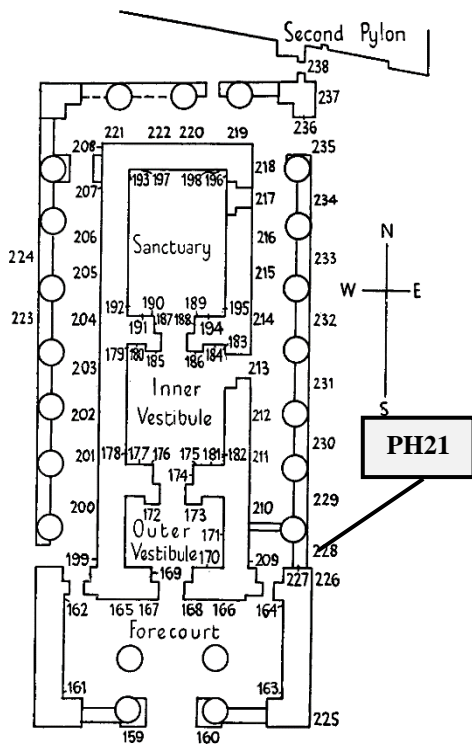

Plan. 6. Philae. Birth House.
(Porter et al., 1939, p.212).
Scenes IDs by the
Author.

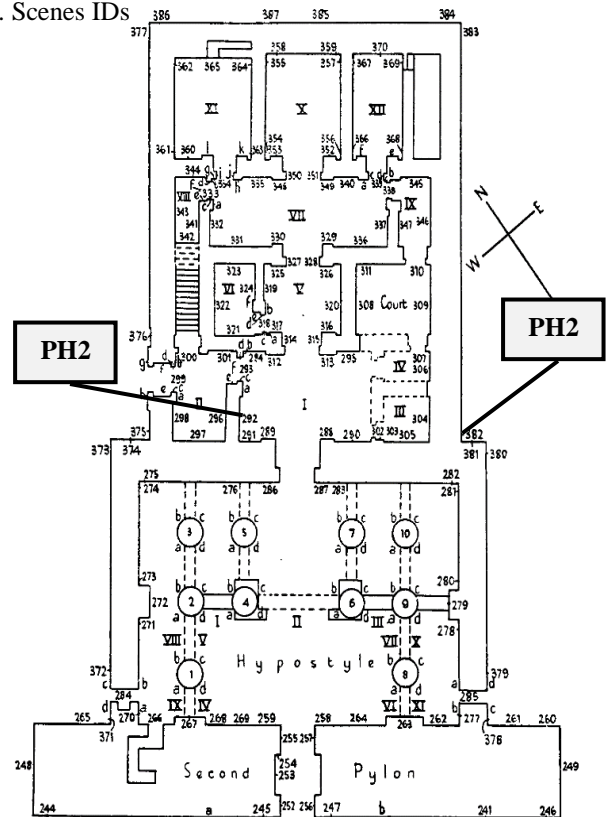

Plan. 7. Philae. Temple of Isis. Main Temple.
(Porter et al., 1939, p.230). Scenes IDs
by the Author.

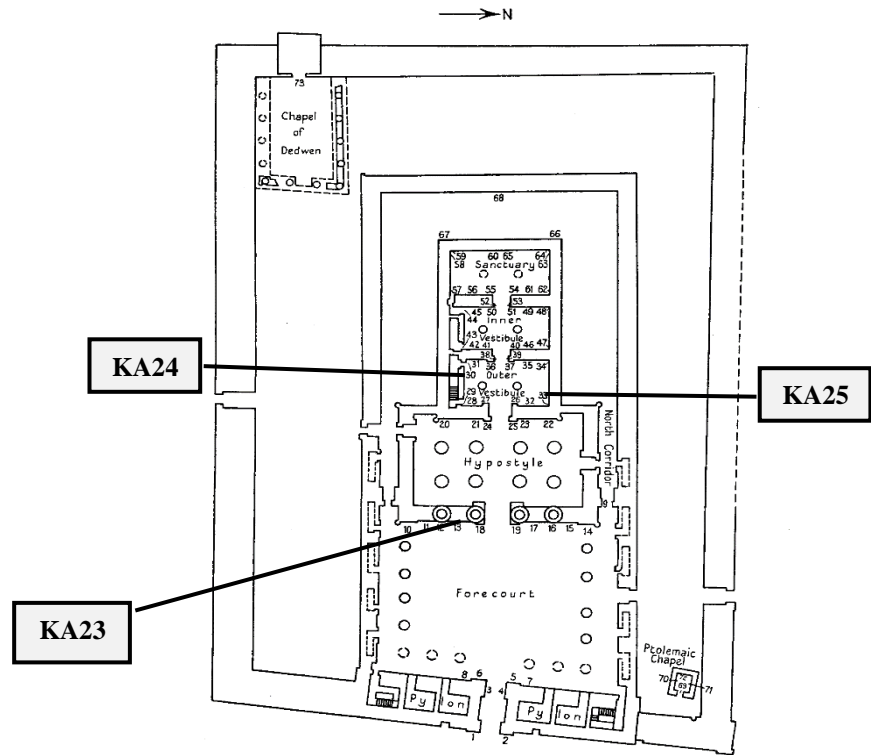

Plan. 8. Temple of Mandulis. Kalabsha.
(Porter et al., 1951, p.12). Scenes IDs added by the Author

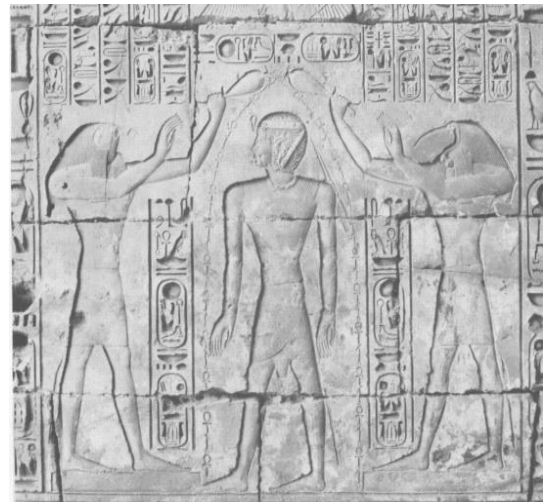

Figure 1: Right, Purification of Seti I, Temple of Abydos, Laukens, D. (2015). The Temples of Ancient Egypt. ANCIENT EGYPT ONLINE. Geraadpleegd op 20 juni 2022, van <https://www.ancient-egypt-online.com/temples-of-ancient-egypt.html> . Left, Purification of Ramesses

Scenes in the Temple of Dendera:



Figure 2: Outer Hypostyle, Intercolumnar walls, Dendera, No. DA2 in temple's plan. © Author

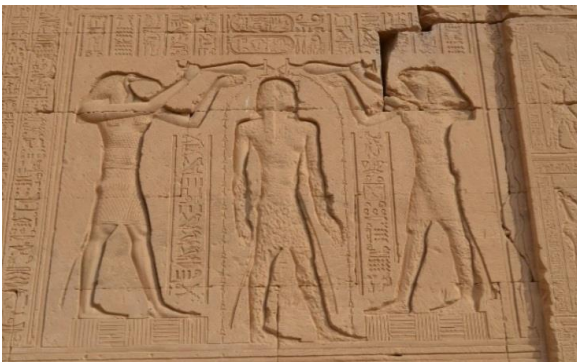

Figure 4 : Exterior. West wall. No DA4 in temple's plan © Author

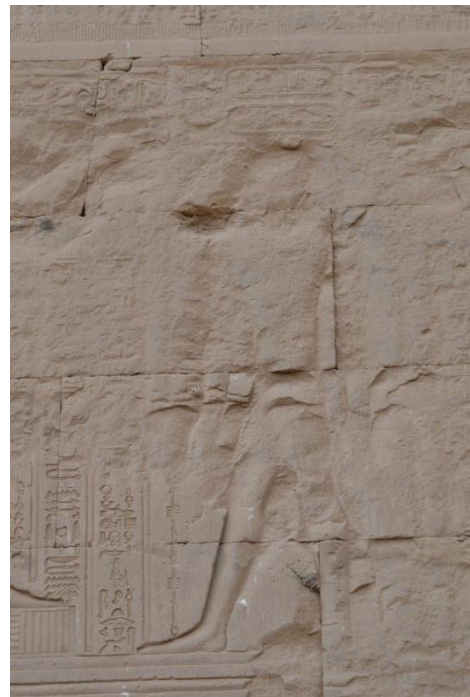

Figure 3: Exterior. East wall. No DA3 in temple's plan, partly damaged but the stream of Ankh, Was and Djed Pillar appears near the king's leg. © Author

Scenes in the Temple of Esna:



Figure 5: Façade of the Hypostyle Hall, No.ES5 in temple's plan. © Author

Scenes in the Temple of Edfu:



Figure 6: Birth House, Northern Exterior. No. ED6 in temple's plan. © Author



Figure 7: Birth House, Southern Exterior of Inner Vestibule No. ED7 in temple's plan. The King is facing Thot. © Author



Figure 8: Forecourt - west south wall. No. ED9 in temple's plan. © Author



Figure 9: Forecourt - east south wall. No. ED10 in temple's plan. © Author

Scenes in the Temple of Kom Ombo



Figure 10: Facade. Intercolumnar wall. The hypostyle room's façade. No. KO17 in temple's plan. © Author



Figure 11: Facade. Intercolumnar wall. The hypostyle room's façade. No. KO18 in temple's plan. © Author



Figure 12: Inner Hypostyle. Room B, west wall. No. KO19 in temple's plan. © Author



Figure 13: Room C or Outer Vestibule (side west, north wall, partly damaged). No. KO20 in temple's plan. © Author

Scenes in the Temple of Philae



Figure 14: Temple of Isis. Inner part of Temple, Room I (PH22). © Author

Scenes in the Temple of Kalabsha



Figure 15: Hypostyle. Façade, (KA24)
Intercolumnar wall. © Author



Figure 16: Outer Vestibule (KA25). ©
Author

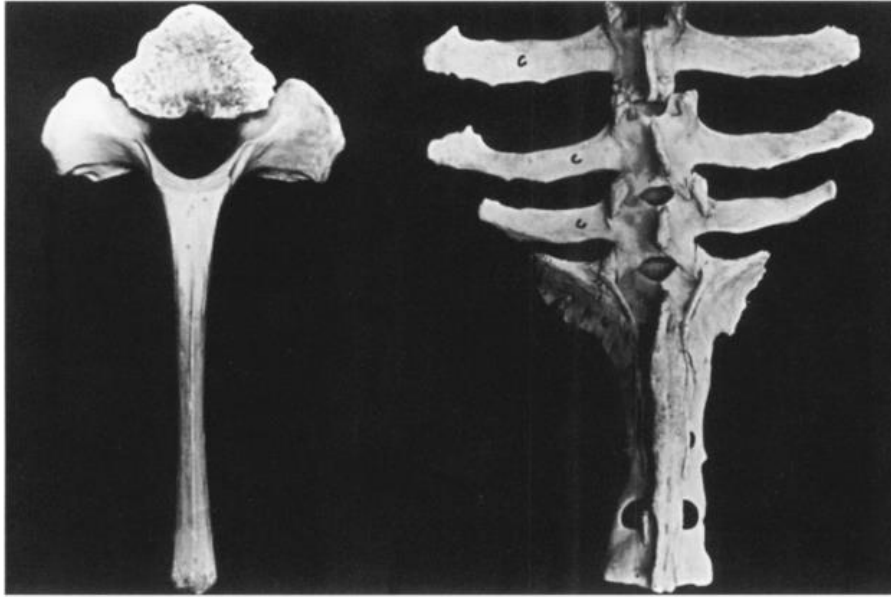

Fig. 17. A bull's thoracic vertebra (left) showing its similarity to an ankh; sacrum plus last three lumbar vertebrae of a bull (right), similarity to a Djed pillar. (Gordon et al., 1995, fig.1).

References

- ¹ Sales, J. D. C. (2019). Political ideas expressed by visual narratives: the case of the Ptolemaic Egyptian temples. *BAEDE, Boletín de la Asociación Española de Egiptología*, 95-124.
- ² Arnold, D., Haeny, G., Bell, L., & Finnestad, R. B. (1997). *Temples of ancient Egypt*. Cornell University Press.
- ³ Sales, J. D. C. (2019). Political ideas expressed by visual narratives: the case of the Ptolemaic Egyptian temples. *BAEDE, Boletín de la Asociación Española de Egiptología*, 95-124.
- ⁴ Gardiner, A. (1950). The Baptism of Pharaoh. *The Journal of Egyptian Archaeology*, 36(1), 3-12.
- ⁵ Ivanov, K. (2017). Pr-dw3t - The House of Morning Adoration. Egyptology MA University of Copenhagen.
- ⁶ Sales, J. D. C. (2019). Political ideas expressed by visual narratives: the case of the Ptolemaic Egyptian temples. *BAEDE, Boletín de la Asociación Española de Egiptología*, 95-124.
- ⁷ Aurell, J. (2020). *Medieval Self-Coronations: The History and Symbolism of a Ritual*. Cambridge University Press.
- ⁸ Von Bomhard, A. S. (2012). Decree of Saïs: The Stelae of Thonis-Heracleion and Naukratis. Oxford Centre for Maritime Archeology, p.41.
- ⁹ Delia, D. (1992). The refreshing water of Osiris. *Journal of the American Research Center in Egypt*, 29, 181-190.
- ¹⁰ Traunecker, C. (1972). Les rites de l'eau à Karnak d'après les textes de la rampe de Taharqa. *Bulletin de l'Institut Français d'Archéologie Orientale du Caire*, (72), 195-236.
- ¹¹ Gordon, A. H., Gordon, A. A., & Schwabe, C. W. (1995). The Egyptian w3s-Scepter and its Modern Analogues: Uses as Symbols of Divine Power or Authority. *Journal of the American Research Center in Egypt*, 185-196.
- ¹² Gardiner, A. (1950). The Baptism of Pharaoh. *The Journal of Egyptian Archaeology*, 36(1), 3-12.
- ¹³ Blackman, A. M. (1998). *Gods, priests, and men: Studies in the religion of Pharaonic Egypt*. Routledge.
- ¹⁴ Gardiner, A. (1950). The Baptism of Pharaoh. *The Journal of Egyptian Archaeology*, 36(1), 3-12, p.3.
- ¹⁵ Landgráfová, R. (2011). The oldest known scene of the purification of the King. "Times, signs and pyramids: studies in honour of Miroslav Verner on the occasion of his seventieth birthday, 162-165.
- ¹⁶ Aurell, J. (2020). *Medieval Self-Coronations: The History and Symbolism of a Ritual*. Cambridge University Press, p.64.
- ¹⁷ Blackman, A. M. (1998). *Gods, priests, and men: Studies in the religion of Pharaonic Egypt*. Routledge, p.9.
- ¹⁸ Gardiner, A. (1950). The Baptism of Pharaoh. *The Journal of Egyptian Archaeology*, 36(1), 3-12, p.7.
- ¹⁹ Blackman, A. M. (1918). The House of the morning. *The Journal of Egyptian Archaeology*, 5(1), 148-165.
- ²⁰ Brandon, S. G. F. (1968). "The Life-Giving Significance of Lustration in the Osirian Mortuary Ritual and in Primitive Christian Baptism." In *Guilt or Pollution and Rites of Purification*, edited by Herbert W. Schneider and B. A. Van Proosdij, pp. 52-53. Proceedings

of the xith International Congress of the International Association for the History of Religions, volume 2. Leiden: E. J. Brill, p.52.

²¹ Gardiner, A. (1950). The Baptism of Pharaoh. *The Journal of Egyptian Archaeology*, 36(1), 3-12, p.3.

²² Corcoran, L. H. (1995). Portrait mummies from Roman Egypt:(I-IV centuries AD); with a catalogue of portrait mummies in Egyptian museums. The Oriental Institute of the University of Chicago, p.59.

²³ Jéquier, G. (1946). *Considérations sur les religions égyptiennes*, p.82.

²⁴ Gabriel, R. A. (2002). *Gods of our fathers: the memory of Egypt in Judaism and Christianity* (Vol. 67). Greenwood Publishing Group.

²⁵ Sales, J. D. C. (2019). Political ideas expressed by visual narratives: the case of the Ptolemaic Egyptian temples. *BAEDE, Boletín de la Asociación Española de Egiptología*, 95-124.

²⁶ Faulkner, R. O. (1964). *A concise dictionary of Middle Egyptian*.

²⁷ Gardiner, A.H. (1957). *Egyptian grammar: being an introduction to the study of hieroglyphs*. Griffith Institution.

²⁸ Budge, E. W. (1981). *An Egyptian Hieroglyphic Dictionary*. Рипол Классик.

²⁹ Ibid.

³⁰ Thibaud, R. J. (2019). *Dictionnaire de mythologie et de symbolique égyptienne*. Dervy.

³¹ Ivanov, K. (2017). Pr-dw3t - The House of Morning Adoration. Egyptology MA University of Copenhagen.

³² Ibid.

³³ Gardiner, A. (1950). The Baptism of Pharaoh. *The Journal of Egyptian Archaeology*, 36(1), 3-12.

³⁴ Ivanov, K. (2017). Pr-dw3t - The House of Morning Adoration. Egyptology MA University of Copenhagen, p.82, note 21.

³⁵ Otto, E. (1938). Thot als Stellvertreter des Seth. *Orientalia*, 7, 69-79.

³⁶ Gardiner, A. (1950). The Baptism of Pharaoh. *The Journal of Egyptian Archaeology*, 36(1), 3-12, p.9.

³⁷ Ibid, p.12.

³⁸ Jéquier, G. (1946). *Considérations sur les religions égyptiennes*, p.83.

³⁹ Ibid.

⁴⁰ Labrique, F. (1992). *Stylistique et théologie à Edfou: le rituel de l'offrande de la campagne: étude de la composition* (Vol. 51). Peeters Publishers, p.173.

⁴¹ Ivanov, K. (2017). Pr-dw3t - The House of Morning Adoration. Egyptology MA University of Copenhagen, p.3.

⁴² Gardiner, A. (1950). The Baptism of Pharaoh. *The Journal of Egyptian Archaeology*, 36(1), 3-12, p.12.

⁴³ Netzley, P. (2003). *Ancient Egypt* (Greenhaven Encyclopedias) (0 editie). Greenhaven Press.

⁴⁴ Mark, J.J. (2017). Ancient Egyptian Symbols. *World History Encyclopedia*. Accessed, May 20, 2022, <https://www.worldhistory.org/article/1011/ancient-egyptian-symbols/>

⁴⁵ Bunson, M. (2014). *Encyclopedia of ancient Egypt*. Infobase Publishing.

⁴⁶ Ellis, N. (2020). *Hieroglyphic Words of Power: Symbols for Magic, Divination, and Dreamwork*. Simon and Schuster.

⁴⁷ Bunson, M. (2014). *Encyclopedia of ancient Egypt*. Infobase Publishing.

- ⁴⁸ Brandon, S. G. F., Gray, J., Griffiths, G. J., Gurney, O. R., & Mallowan, M. (2014). *Beliefs, Rituals, and Symbols of Ancient Egypt, Mesopotamia, and the Fertile Crescent (Man, Myth, and Magic)*. Cavendish Square.
- ⁴⁹ Mark, J. J. (2016). The Ankh. *World History Encyclopedia*. Accessed, 19 May 2022, <https://www.worldhistory.org/Ankh/>
- ⁵⁰ Chevalier, J., & Gheerbrant, A. (1996). *Dictionary of Symbols*. Translated by Buchanan-Brown, J. London: Penguin, p.27.
- ⁵¹ Gordon, A., & Schwabe, C. (2004). *The quick and the dead: Biomedical theory in ancient Egypt*. Brill, p.74.
- ⁵² Budge, E. A. W. (1904). *The Gods of the Egyptians: Or, Studies in Egyptian Mythology (Vol. 1)*. Methuen & Company.
- ⁵³ McDonald, J. A. (2018). Influences of Egyptian Lotus symbolism and ritualistic practices on sacral tree worship in the fertile crescent from 1500 BCE to 200 CE. *Religions*, 9(9), 256, p.8.
- ⁵⁴ Ibid.
- ⁵⁵ Budge, E. A. W. (1904). *The Gods of the Egyptians: Or, Studies in Egyptian Mythology (Vol. 1)*. Methuen & Company.
- ⁵⁶ Mark, J. J. (2016). The Ankh. *World History Encyclopedia*. Accessed, 19 May 2022, <https://www.worldhistory.org/Ankh/>
- ⁵⁷ Wilkinson, R. H. (1994). *Symbol & magic in Egyptian art*. Thames and Hudson.
- ⁵⁸ Mark, J.J. (2017). Ancient Egyptian Symbols. *World History Encyclopedia*. Accessed, May 20, 2022, <https://www.worldhistory.org/article/1011/ancient-egyptian-symbols/>
- ⁵⁹ Piplani, N. (2020). *Hieroglyphics Key: A Challenge To Egyptologists*. Narender Piplani.
- ⁶⁰ Netzley, P. (2003). *Ancient Egypt (Greenhaven Encyclopedias) (0 editie)*. Greenhaven Press.
- ⁶¹ Gordon, A. H., Gordon, A. A., & Schwabe, C. W. (1995). The Egyptian w3s-Scepter and its Modern Analogues: Uses as Symbols of Divine Power or Authority. *Journal of the American Research Center in Egypt*, 185-196.
- ⁶² Jay, N. (2022). Was Scepter – Egyptian Mythology. *Symbol Sage*. Accessed May 26, 2022, from <https://symbolsage.com/was-scepter-egyptian-mythology/>
- ⁶³ Gordon, A. H., Gordon, A. A., & Schwabe, C. W. (1995). The Egyptian w3s-Scepter and its Modern Analogues: Uses as Symbols of Divine Power or Authority. *Journal of the American Research Center in Egypt*, 185-196.
- ⁶⁴ Ibid.
- ⁶⁵ Porter, B., & Moss, R. L. (1939). *Topographical bibliography of ancient Egyptian hieroglyphic texts, reliefs, and paintings. VI. Upper Egypt: chief temples. (Excluding Thebes)*. Topographical bibliography of ancient Egyptian hieroglyphic texts, reliefs, and paintings.
- ⁶⁶ Porter, B., Moss, R. L., & Burney, E. W. (1951). *Topographical Bibliography of Ancient Egyptian Hieroglyphic Texts, Reliefs and Paintings. VII. Nubia, the Deserts and Outside Egypt*. Clarendon Press.



ملاحظات اضافية حول مناظر التطهير في المعابد اليونانية الرومانية بصعيد مصر

وسام فكرى إبراهيم موسى

قسم الإرشاد السياحي - كلية السياحة والفنادق - جامعة مطروح

الملخص

معلومات المقالة

تقدم هذه الورقة دراسة تحليلية مقارنة لمشاهد محددة تم تصويرها على جدران ستة معابد إلهية يونانية ورومانية بصعيد مصر. وهي دندرة وإسنا وإدفو وكوم أمبو وفيلا وكلابشة. في الواقع، باستخدام المفردات الإبداعية المتاحة لهم، قام البطالمة الذين تبجحهم الأباطرة الرومان بتزيين جدران تلك المعابد العظيمة بنقوش ومشاهد ذات قيمة رمزية عالية. وهكذا، تركز الدراسة على تصوير حكام البطالمة والرومان وهم يرتدون الملابس والشعارات والرموز المصرية التقليدية، ويتم تطهيرهم عادة كملوك مصريين.

هدفت المنهجية المتبعة إلى تحليل هذه المشاهد ومقارنتها بالمشاهد المصرية القديمة المقابلة من حيث الموقع والتفاصيل والشخصيات المصورة. كشفت النتائج عن بعض الابتكارات والتطورات المميزة بالإضافة إلى التأكيد على أن هذا النوع من التمثيل يذهب ليكون أكثر من مجرد تقليد ديني، بل له أحياناً طابع سياسي يبرر القيمة الإيديولوجية والدعاية الهادفة المرتبطة به. يتم تأكيد مكانة الملكية من خلال هذه الروايات المرئية التعبيرية، والتي، بناءً على الدراسة الميدانية، غالباً ما تكون في المواقع التي كان للجمهور فيها وصول غير مقيد. كل ذلك بهدف قبولهم كملوك شرعيين وخلفاء للملوك المصريين القدماء.

الكلمات المفتاحية

مناظر التطهير؛
المعابد اليونانية
الرومانية؛ صعيد
مصر؛ الرموز
المصرية القديمة.

(JAAUTH)

المجلد ٢٣، العدد ١،
(٢٠٢٢)،
ص ١٦-٤٢.